

Robotics

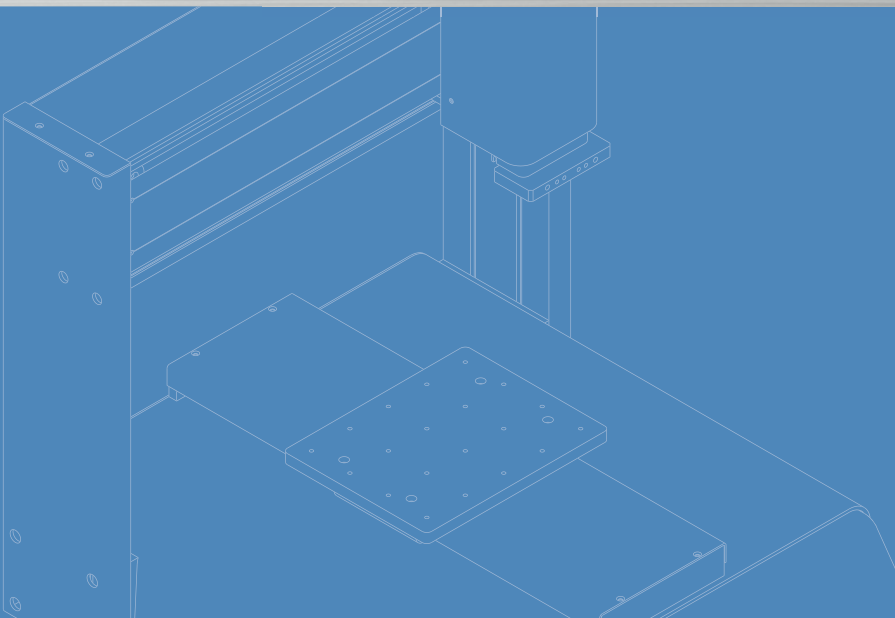

Index

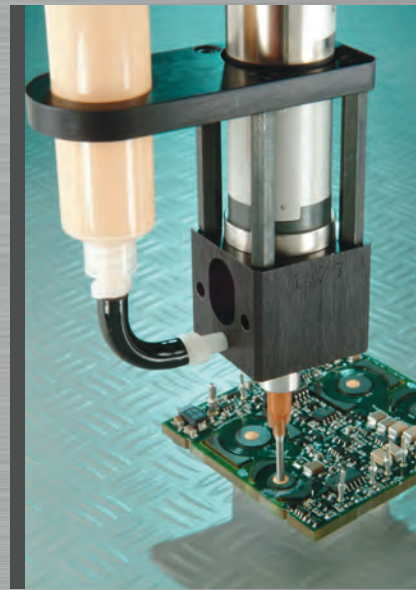
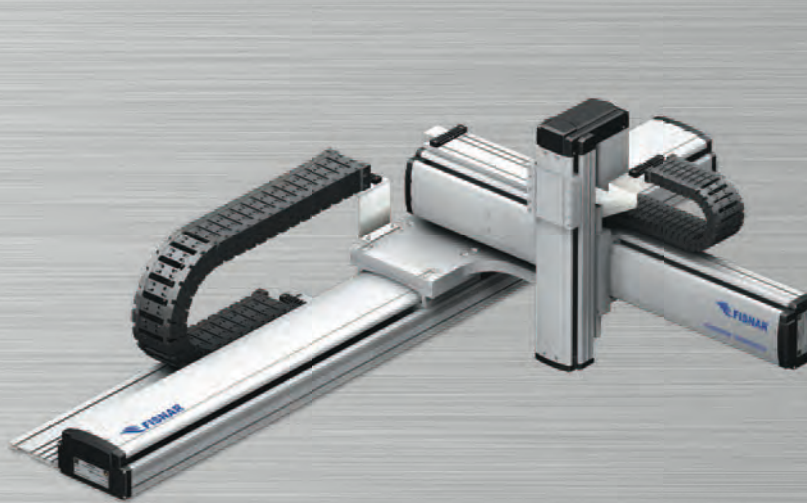

1 Introducing Advances in Robotics

2-5 **Optima Series Benchtop Robots**

F7300N 3 & 4 Axes 300 x 300mm Work Area
F7400N 3 & 4 Axes 400 x 400mm Work Area
F7000NV *Optima* Series Vision System
F7900N 3 Axes 200 x 200mm Work Area

6-10 **Plus Series Benchtop Robots**

F4300N 3 Axes 300 x 300mm Work Area
F4400N 3 Axes 400 x 400mm Work Area
F4500N 3 Axes 500 x 500mm Work Area
F4200N 3 Axes 200 x 200mm Work Area
F5200N UNITOP™ 200 x 200mm Work Area

11-13 **Exacta Series Benchtop Robots**

F3300N 3 & 4 Axes 300 x 300mm Work Area
F3400N 3 & 4 Axes 400 x 400mm Work Area
F3000N 3 Axes Dual Table

14-17 **Lotus Series Benchtop Robots**

F2200N 3 & 4 Axes 200 x 200mm Work Area
F2300N 3 & 4 Axes 300 x 320mm Work Area
F2400N 3 & 4 Axes 400 x 400mm Work Area
F2500N 3 & 4 Axes 510 x 510mm Work Area

18-21 **Gantry Series Robots**

F9300N 3 & 4 Axes 300 x 300mm Work Area
F9600N 3 & 4 Axes 600 x 600mm Work Area
F9800N 3 & 4 Axes 800 x 600mm Work Area
F9250N 3 & 4 Axes - Solar Industry Standard

22-23 **Cantilever Series Robots**

F8800N 3 & 4 Axes 800 x 600mm Work Area
F8100N 3 & 4 Axes 1000 x 800mm Work Area

24 **SCARA Robot**

F2004N 4 Axes 300 x 300 Work Area

25 **Benchtop Rotary and Z-Axis Systems**

RT404 - Rotary dispense system 0-900° circles
Z620 - Z-Axis Dispense System 50mm Vertical Travel

Introducing Advances in Robotics

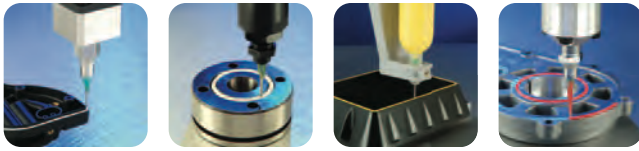

Features

- Dots, lines, circles & arcs
- Simple programming
- Three and four axes models
- Suitable for a wide range of dispensing
- Interpolates in all axes
- CE and RoHS compliant Robots



F7000N Benchtop - *Optima* - Series

Introducing the enhanced 32 bit F7000N series with upgraded features. These systems offer improved speed, reliability and performance with micron measured reliability and resolution. Maximum point capacity is 5 million. F7000N *Optima* robots are available in three and four axes models. Fisnar robots interpolate lines and curves in all axes. Robots are equipped with an easy-to-use teach pendant for simple programming using Fisnar proven user-friendly software, providing simple prompts that enable a program to be operational within minutes.

F4000N & F5000N Benchtop - *Plus* - Series

An excellent value benchtop robot series with a proven record of accuracy and reliability. The *Plus* series includes upgraded components that result in a quieter and more efficient operation. Programs are stored on board and a USB drive is provided for easy program transfer and off-robot storage. F4000N & F5000N robots are equipped with an easy-to-use teach pendant for simple programming using Fisnar proven user-friendly software, providing simple prompts that enable a program to be operational within minutes.

F3000N Benchtop - *Exacta* - Series - Servo Ball Screw Drives - Heavy Duty

Highly accurate, closed-loop positioning robots with ball-screw drives. Manufactured for low vibration and rugged operating efficiency. The new robust F3000N *Exacta* series include proven servo drive technology. Closed-loop technology provides fail safe operation. Programs are stored on board the robot but may be uploaded and downloaded by RS232 port. F3000N robots are equipped with an easy-to-use teach pendant for simple programming using Fisnar proven user-friendly software, providing simple prompts that enable a program to be operational within minutes.

F2000N Benchtop - *Lotus* - Series

The original benchtop series robots offering superior I/O electronics and enhanced programming software. Robots are equipped with a teach pendant for simple programming. Programs are stored on board the robot; alternatively an optional software package allows programming, editing and storage off line. Robots are available in CE and non CE models.

F9000N & F8000N Gantry & Cantilever Series

Gantry and Cantilever designs have several distinguishable uses - conveyorized production lines, spray applications and applications requiring heavier dispensing systems such as Meter & Mixing two-part equipment, Hot Melt systems and custom sizes with longer Z axis reach. They are particularly suited to the Solar assembly industry as these robots can be manufactured to any required size. Standard sizes are featured in this brochure. F9000N and F8000N robots are equipped with an easy-to-use teach pendant for simple programming. Optional bar coded identity software is available.

F2004N SCARA Robot - Selective Compliance Assembly Robot Arm

An high speed industrial SCARA robot, ideal for high volume dispensing and pick & place applications requiring greater flexibility for automated manufacturing environments, including conveyors and work cells. The F2004N robot is equipped with an easy-to-use teach pendant for simple programming using Fisnar proven user-friendly software, providing simple prompts that enable a program to be operational within minutes.

RT404 & Z620 Benchtop Rotary table and Z-Axis Dispense Systems

The RT404 is a rugged semi-automatic, dual-head rotary dispensing table, designed for either foot pedal or hand operated control. Dispensing valves or syringes maybe mounted on the two heads and angled so that they can dispense circular beads either inside or outside an object. The Z620 Z-Axis motion system ideal solution for repetitive filling, potting and other dispensing operations requiring a simple up and down operation.

F7300N - 3 & 4 Axes

Working Area 300 x 300mm



Features

- Ideal for form-in-place gaskets, adhesives, potting, coating and filling
- High Resolution 0.001mm
- Performs continuous path and point-to-point motions
- Quick fluid-purge button located on front panel
- Software tip alignment routine for quick program offsets when changing dispensing tips
- Step-and-repeat functions – program one object only for multiple identical objects
- On board 100 programs, 5 million point memory capacity, 50,000 points per program
- USB connector allows system updates and program interchange between robots
- Available without Teach Pendant for multiple installations.

The model F7300N is a RoHS compliant upgrade to the popular 11.81" x 11.81" (300 x 300mm) benchtop robot. This internationally accepted robot maintains the compact style and functionality of design, providing a precision multiple axis robot ideal for many bench dispensing projects. Resolution is 1 micron and interpolation is in all axes. The F7300N has been engineered to accept a tool weight of up to 5kg and a worktable load of 10kg, making the system tough enough for a wide range of automated dispensing applications.

Dimensions

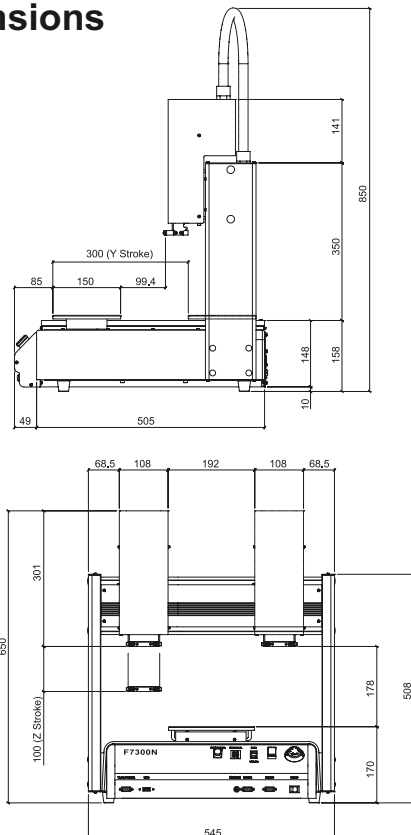

Model

F7300N Robot 3-axes 110/220V
 F7304N Robot 4-axes 110/220V

Accessories (optional)

562008C External start box
 DSP501LF Dispenser
 F7000N-WIN Windows® software package

Specifications

X/Y/Z Work area (mm):	300 / 300 / 100 4th axis +/-360°
Worktable load / Tool:	10 kg. / 5 kg.
Max. Speed X&Y / Z:	800 / 320 (mm/sec)
Repeatability:	+/- 0.02mm/ Axis
Resolution:	0.001mm/ Axis
Data Memory:	100 Programs 50,000 points / program
Processor:	32 Bit
Drive Sys. / Stepping motor:	5-phase micro stepping motor
Motion Control:	PTP & CP
Teaching Method:	Teach Pendant
I/O signals:	8 inputs / 8 outputs
External Interface:	USB / RS232
Power Supply:	Auto-switching AC100-240 - 300 Watts
Dimensions (WxDxH):	545 x 554 x 850
Weight:	82.5 lbs (37.5 kg)

F7400N - 3 & 4 Axes

Working Area 400 x 400mm

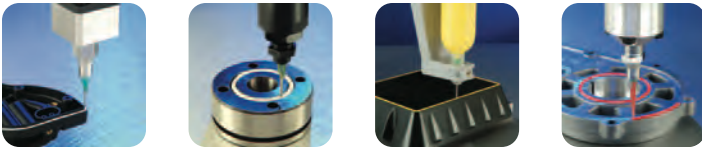

Features

- Ideal for form-in-place gaskets, adhesives, potting, coating and filling
- High Resolution 0.001mm
- Performs continuous path and point-to-point motions.
- Quick fluid-purge button located on front panel
- Software tip alignment routine for quick program offsets when changing dispensing tips
- Step-and-repeat functions – program one object only for multiple identical objects
- On board 100 programs, 5 million point memory capacity, 50,000 points per program
- USB connector allows system updates and program interchange between robots
- Available without Teach Pendant for multiple installations



The model F7400N dispensing robot has the largest working area in the F7000N series at 15.75" x 15.75" (400 x 400mm). Fisnar Inc. robots interpolate in all axes for 3D dispensing of adhesives, silicones and UV Cure resins. It is also possible to mount a vacuum pick and place system coupled with automatic dispensing equipment for dispense and place operations. Resolution is 1 micron and interpolation is in all axes. The F7400N has been engineered to accept a tool weight of up to 5kg and a worktable load of 10kg, making the system tough enough for a wide range of automated dispensing applications.

Model

F7400N Robot 3-axes 110/220V
 F7404N Robot 4-axes 110/220V

Accessories (optional)

562008C External start box
 DSP501LF Dispenser
 F7000N-WIN Windows® software package

Specifications

X/Y/Z Work area (mm):	400 / 400 / 100 4th axis +/-360°
Worktable load / Tool:	10 kg. / 5 kg.
Max. Speed X&Y / Z:	800 / 320 (mm/sec)
Repeatability:	+/- 0.02mm/ Axis
Resolution:	0.001mm/ Axis
Data Memory:	100 Programs 50,000 points / program
Processor:	32 Bit
Drive Sys. / Stepping motor:	5-phase micro stepping motor
Motion Control:	PTP & CP
Teaching Method:	Teach Pendant
I/O signals:	8 inputs / 8 outputs
External Interface:	USB / RS232
Power Supply:	Auto-switching AC100-240 - 300 Watts
Dimensions (WxDxH):	635 x 645 x 850
Weight:	94.6 lbs (43 kg)

Dimensions

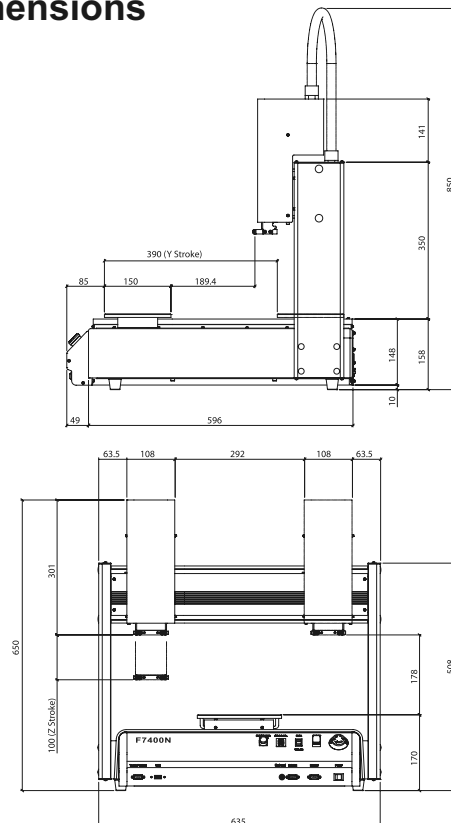

F7000NV - Series Vision System

With Auto Alignment Function

Features

- Ideal for irregular dispensing route per component
- High Resolution 0.001mm
- Automatic offset of dispensing route
- Precision operation
- Increased production efficiency
- Touch screen programming
- Preview simulation of dispense route
- Auto offset of coordinates after tip change
- Edit programs directly - easy learn - fast response
- CAD DXF and Excel accepted
- Optional LED light accessories for light conditions



Model (complete system)

F7300NV	3-axes Robot 300x300mm 110/220V CE
F7400NV	3-axes Robot 400x400mm 110/220V CE

Accessories (optional)

F7001NZ	4X zoom lens
DSP501LF	Dispenser



Detail

Touch screen programming with simulation preview.

Vision system includes:

- Robot 3 axes - optional 300 x 300mm or 400 x 400mm
- Touch screen PC
- Software
- Color camera
- Camera control
- Exlite Cognate in-sight white LED
- CCD conversion ring (20.40.60mm)
- CCD fixture, LSC light fixture, control system fixture
- Frame capture dongle USB, extended line, LAN cable

The vision system is supplied complete including the PC, ensuring all components are compatible, thereby eliminating any costly start-up issues and reducing the learning curve.

The system is designed to provide automatic dispensing program offsets when the dispensing path of a component cannot be guaranteed.

Accepts CAD, DXF and Excel formats for dispense paths. Commonly two fiducial points are used to provide program offsets, however one is also possible.

Optional LED's may be required depending on refractive surface.



Specifications

X/Y/Z Work area (mm):	300 / 300 / 100 or 400 / 400 / 100
Vision Software:	Robot Vision
System Operation:	Touch Screen Computer (All in One)
Camera:	USB Color Camera
Interface Port:	LAN
Frame Grabber:	USB Dongle
Light System:	EXLITE Cognate In-Sight White LED
Lens:	4X (optional)
Teaching Method:	1. PC Software, 2. Screen Touch, 3. Teach Pendant
Software Function:	1. Program Edit, 2. Auto Vision Align, 3. Accept DXF Files

F7900N - 3 Axes

Working Area 200 x 200mm

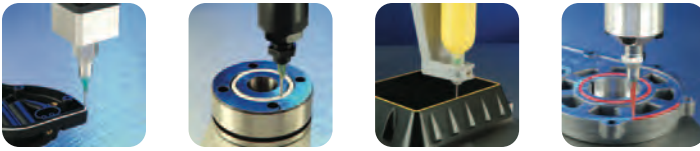

Features

- High resolution 0.02mm
- On board 100 programs, 400,000 point memory capacity, 4,000 points per program
- Performs continuous path and point-to-point motions
- Quick fluid-purge button located on front panel
- Software tip alignment routine for quick program offsets when changing dispensing tips
- Step-and-repeat functions – program one object only for multiple identical objects
- Ideal for form-in-place gaskets, adhesives, potting, coating and filling
- USB connector allows system updates and program interchange between robots by flash memory card
- Available without Teach Pendant for multiple installations



A powerful compact-sized desktop robot with a working area of 7.87" x 7.87" (200 x 200mm). Its reduced benchtop footprint makes it an ideal robot for automating a current manual dispensing application.

Programming is carried out by a teach-pendant (included) using the industry's leading dispensing software that walks the user through step-by-step instructions to create a sophisticated dispensing operation in minutes.

Model

F7900N 3-axes robot 110/220V

Accessories (optional)

562008C	External start box
DSP501LF	Dispenser
F7000N-WIN	Windows® software package

Specifications

X/Y/Z Work area (mm):	200 / 200 / 50
Worktable load / Tool:	3 kg. / 1 kg.
Max. Speed X&Y / Z:	500 / 250 (mm/sec)
Repeatability:	+/- 0.04mm/ Axis
Resolution:	0.02mm/ Axis
Data Memory:	100 Program 4,000 points / program
Drive Sys. / Stepping motor:	3-phase
Motion Control:	PTP & CP
Teaching Method:	Teach Pendant
I/O signals:	4 inputs / 4 outputs
External Interface:	USB / RS232
Power Supply:	AC 95-132V - AC 180-250V
Dimensions (WxDxH):	323 x 443 x 437
Weight:	22 lbs (10 kg)

Dimensions

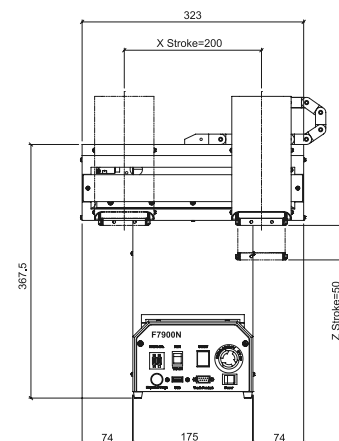
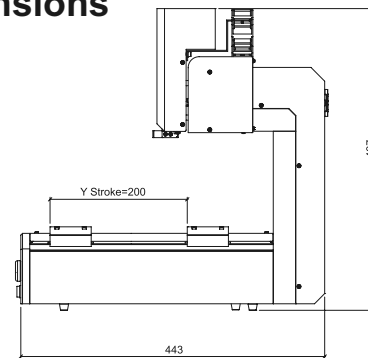

F4300N - 3 Axes

Working Area 300 x 300mm

Plus



Features

- High resolution 0.001mm
- On board 100 programs, 400,000 point memory capacity, 4,000 points per program
- Performs continuous path and point-to-point motions
- Quick fluid-purge button located on front panel
- Software tip alignment routine for quick program offsets when changing dispensing tips
- Step-and-repeat functions – program one object only for multiple identical objects
- Ideal for form-in-place gaskets, adhesives, potting, coating and filling
- Available without Teach Pendant for multiple installations
- USB connector allows system updates and program interchange between robots

A powerful compact-sized desktop robot with a working area of 11.81" x 11.81" (300 x 300mm). Its reduced benchtop footprint makes it an ideal robot for automating a current manual dispensing application. Programming is carried out by a teach-pendant (included) using the industry's leading dispensing software that walks the user through step-by-step instructions to create a sophisticated dispensing operation in minutes.

Dimensions

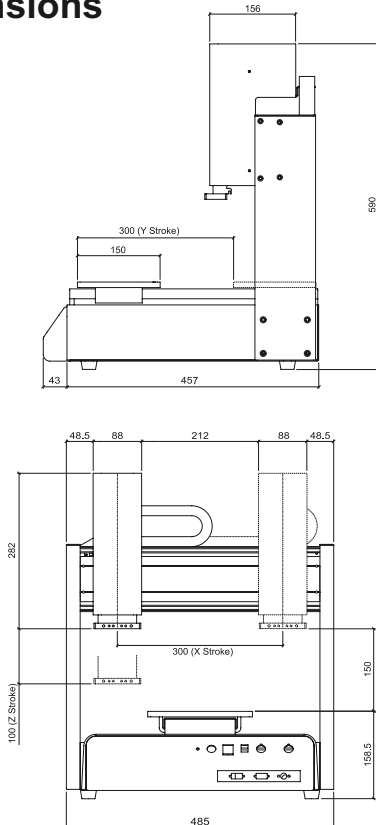

Model

F4300N

Robot 3-axes 110/220V

Accessories (optional)

- | | |
|------------|---------------------------|
| 562008C | External start box |
| DSP501LF | Dispenser |
| F4000N-WIN | Windows® software package |

Specifications

X/Y/Z Work area (mm):	300 / 300 / 100
Worktable load / Tool:	10 kg. / 5 kg.
Max. Speed X&Y / Z:	800 / 320 (mm/sec)
Repeatability:	+/- 0.02mm/ Axis
Resolution:	0.001mm/ Axis
Data Memory:	100 Programs 4,000 points / program
Drive Sys. / Stepping motor:	3-phase
Motion Control:	PTP & CP
Teaching Method:	Teach Pendant
I/O signals:	8 inputs / 8 outputs
External Interface:	USB / RS232
Power Supply:	AC 95-132V, AC 180-250V
Dimensions (WxDxH):	485 x 500 x 590
Weight:	66 lbs (30 kg)

F4400N - 3 Axes

Working Area 400 x 400mm

Plus

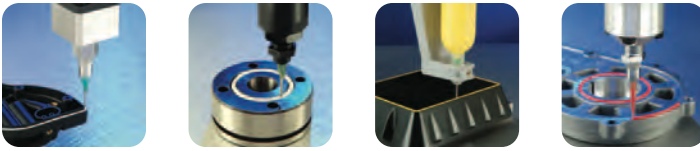

Features

- Ideal for form-in-place gaskets, adhesives, potting, coating and filling
- High resolution 0.001mm
- Performs continuous path and point-to-point motions
- Quick fluid-purge button located on front panel
- Software tip alignment routine for quick program offsets when changing dispensing tips
- Step-and-repeat functions – program one object only for multiple identical objects
- On board 100 programs, 400,000 point memory capacity, 4,000 points per program
- Available without Teach Pendant for multiple installations
- USB connector allows system updates and program interchange between robots



The model F4400N provides a generous working area of 15.75" x 15.75" (400 x 400mm). Fisnar robots interpolate in all axes for 3D dispensing of adhesives, silicones and UV Cure resins.

Resolution is 1 micron and interpolation is in all axes. The F4400N has been engineered to accept a tool weight of up to 5kg and a worktable load of 10kg, making the system tough enough for a wide range of automated dispensing applications.

Model

F4400N Robot 3-axes 110/220V

Accessories (optional)

562008C	External start box
DSP501LF	Dispenser
F4000N-WIN	Windows® software package

Specifications

X/Y/Z Work area (mm):	400 / 400 / 100
Worktable load / Tool:	10 kg. / 5 kg.
Max. Speed X&Y / Z:	800 / 320 (mm/sec)
Repeatability:	+/- 0.02mm/ Axis
Resolution:	0.001mm/ Axis
Data Memory:	100 Programs 4,000 points / program
Drive Sys. / Stepping motor:	3-phase
Motion Control:	PTP & CP
Teaching Method:	Teach Pendant
I/O signals:	8 inputs / 8 outputs
External Interface:	USB / RS232
Power Supply:	AC 95-132V, AC 180-250V
Dimensions (WxDxH):	530 x 600 x 596
Weight:	88 lbs (40 kg)

Dimensions

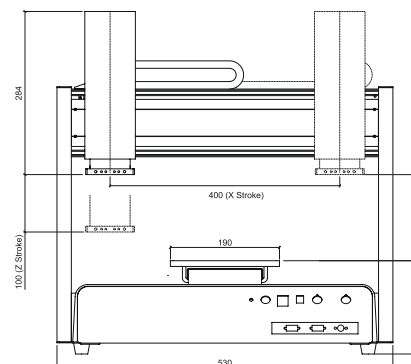
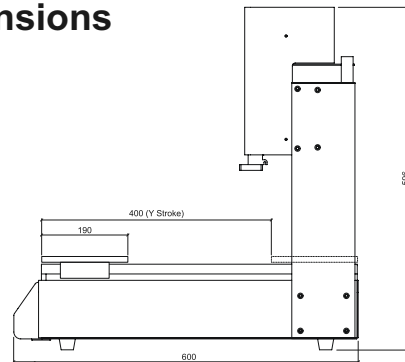

F4500N - 3 Axes

Working Area 500 x 500mm

Plus



Features

- High resolution 0.001mm
- On board 100 programs, 400,000 point memory capacity, 4,000 points per program
- Performs continuous path and point-to-point motions
- Quick fluid-purge button located on front panel
- Software tip alignment routine for quick program offsets when changing dispensing tips
- Step-and-repeat functions – program one object only for multiple identical objects
- Ideal for form-in-place gaskets, adhesives, potting, coating and filling
- Available without Teach Pendant for multiple installations
- USB connector allows system updates and program interchange between robots

A powerful and optimum sized benchtop robot with a working area of 19.68" x19.68" (500 x 500mm) and extra Z reach of 5.90" (150mm). Ideal for large non contiguous structures and for larger dispensing equipment or apparatus. The F4500N is suitable for plasma treatment applications prior to dispensing. Programming is carried out by a teach-pendant (included) using the industry's leading dispensing software that walks the user through step-by-step instructions to create a sophisticated dispensing operation in minutes.

Dimensions

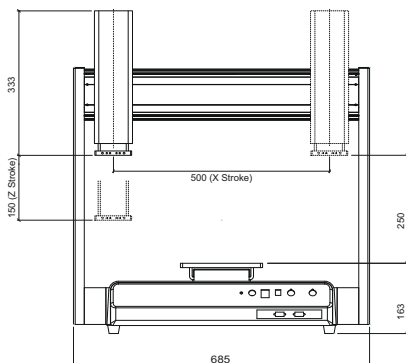
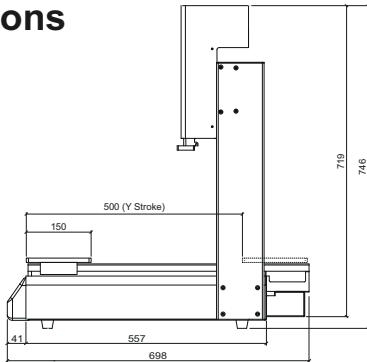

Model

F4500N

Robot 3-axes 110/220V CE

Accessories (optional)

562008C

External start box

DSP501LF

Dispenser

F4000N-WIN

Windows® software package

Specifications

X/Y/Z Work area (mm):	500 / 500 / 150
Worktable load / Tool:	10 kg. / 5 kg.
Max. Speed X&Y / Z:	800 / 320 (mm/sec)
Repeatability:	+/- 0.02mm/ Axis
Resolution:	0.001mm/ Axis
Data Memory:	100 Programs 4,000 points / program
Drive Sys. / Stepping motor:	3-phase
Motion Control:	PTP & CP
Teaching Method:	Teach Pendant
I/O signals:	8 inputs / 8 outputs
External Interface:	USB / RS232
Power Supply:	AC 95-132V, AC 180-250V
Dimensions (WxDxH):	685 x 698 x 746
Weight:	102 lbs (46 kg)

F4200N - 3 Axes

Working Area 200 x 200mm

Plus

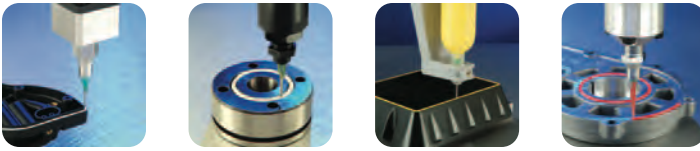

Features

- Ideal for form-in-place gaskets, adhesives, potting, coating and filling
- High resolution 0.001mm
- Performs continuous path and point-to-point motions
- Quick fluid-purge button located on front panel
- Software tip alignment routine for quick program offsets when changing dispensing tips
- Step-and-repeat functions – program one object only for multiple identical objects
- On board 100 programs, 400,000 point memory capacity, 4,000 points per program
- Available without Teach Pendant for multiple installations



The F4200N is a compact and economically priced benchtop robot. Designed for medical and laboratory type environments requiring a streamlined and easily maintained machine. This robot will support most light dispensing applications that require a high performance standard. The bench space reduction is an additional benefit. Programming is simply carried out by a teach pendant (included) using the industry's leading dispensing software that walks the user through step-by-step instructions to create a sophisticated dispensing operation in minutes.

Model

F4200N Robot 3-axes 200x200mm 110/220V

Accessories (optional)

562008C External start box
DSP501LF Dispenser
F4000N-WIN Windows® software package

Specifications

X/Y/Z Work area (mm):	200 / 200 / 50
Worktable load / Tool:	3 kg. / 1 kg.
Max. Speed X&Y / Z:	500 / 200 (mm/sec)
Repeatability:	+/- 0.02mm/ Axis
Resolution:	0.001mm/ Axis
Data Memory:	100 Programs 4,000 points / program
Drive Sys. / Stepping motor:	3-phase micro stepping motor
Motion Control:	PTP & CP
Teaching Method:	Teach Pendant
I/O signals:	8 inputs / 8 outputs
External Interface:	USB / RS232
Power Supply:	AC 95-132V, AC 180-250V
Dimensions (WxDxH):	327 x 500 x 450
Weight:	33 lbs (14.9 kg)

Dimensions

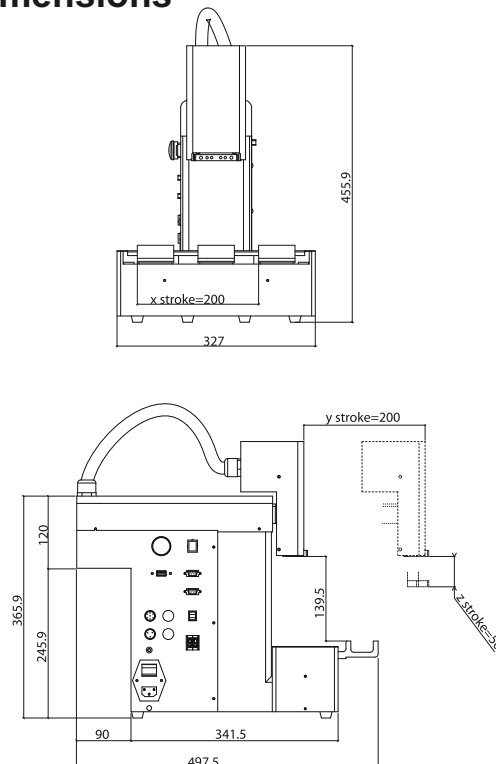

F5200N - 3 Axes Gantry UNITOP™

Working Area 200 x 200mm

Plus



Features

- Ideal for form-in-place gaskets, adhesives, potting, coating and filling
- Place-anywhere UNITOP™ gantry design, allows flexible operation
- High resolution 0.001mm
- Performs continuous path and point-to-point motions
- Quick fluid-purge button located on front panel of controller
- Software tip alignment routine for quick program offsets when changing dispensing tips
- Step-and-repeat functions - program one object only for multiple identical objects
- On board 100 programs, 400,000 point memory capacity, 4,000 points per program
- Available without Teach Pendant for multiple installations
- USB connector allows system updates and program interchange between robots

The model F5200N is a compact and economically priced gantry robot with all moving axes above the workpiece. The Unitop™ is suitable for any platform requiring a gantry type mounting providing open access under the robot. The F5200N is also ideal for conveyor fed automation or installed in work cells operating as a slave robot.

Working area is 7.87" x 7.87" (200 x 200mm). Programming is simply carried out by a teach-pendant (included) using the industry's leading dispensing software that walks the user through step-by-step instructions to create a sophisticated dispensing operation in minutes.

Dimensions

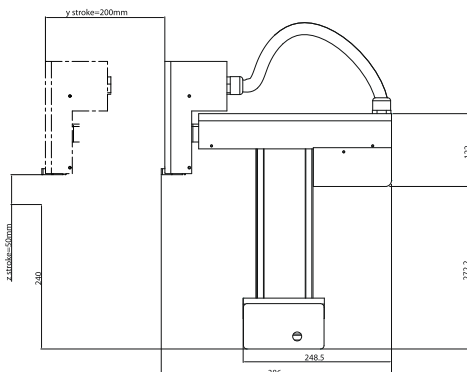
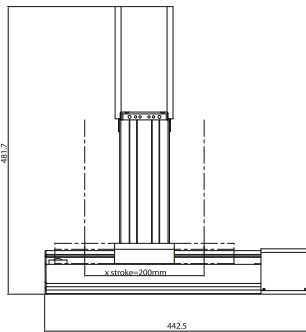

Model

F5200N

Robot UNITOP™ 3-axes 110/220V CE

Accessories (optional)

DSP501LF

Dispenser

F4000N-WIN

Windows® software package

Specifications

X/Y/Z Work area (mm):	200 / 200 / 50
Total load - Z axis:	2 kg.
Max. Speed X&Y / Z:	500 / 300 (mm/sec)
Repeatability:	+/- 0.02mm/ Axis
Resolution:	0.001mm/ Axis
Data Memory:	100 Programs 4,000 points / program
Drive Sys. / Stepping motor:	Micro stepping motor
Motion Control:	PTP & CP
Teaching Method:	Teach Pendant
I/O signals:	8 inputs / 8 outputs
External Interface:	USB / RS232
Power Supply:	AC 110 - 220V
Dimensions (WxDxH):	350 x 330 x 475
Weight:	37.4 lbs (17 kg)

F3300N - 3 & 4 Axes Servo

Working Area 300 x 300mm

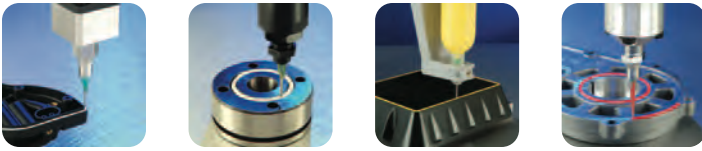

Features

- Robust ball-screw servo motor drives
- Ideal for form-in-place gaskets, adhesives, potting, coating and filling
- High resolution 0.001mm
- Performs continuous path and point-to-point motions
- Quick fluid-purge button located on front panel
- Software tip alignment routine for quick program offsets when changing dispensing tips
- Step-and-repeat functions - program one object only for multiple identical objects
- On board 100 programs, 1,000 points per program
- Memory capacity, 20,000 steps / 20,000 points



The model F3300N is a RoHS compliant 11.81" x 11.81" (300 x 300mm) benchtop robot. It's servo motor driven ball-screw design enables closed loop operation. A rugged aluminum structure helps prevent vibration while maintaining a compact style and functionality, providing a precision multiple axis robot ideal for many bench dispensing projects. Resolution is 1 micron and interpolation is in all axes. The F3300N has been engineered to accept a tool weight of up to 7kg and 4kg for the 4-axes model with a worktable load of 15 kg, making the system tough enough for a wide range of automated dispensing applications.

Model

F3300N Robot 3-axes 220V
 F3304N Robot 4-axes 220V

Accessories (optional)

DSP501LF Dispenser

Specifications

X/Y/Z Work area (mm):	300 / 300 / 100	R-axis +/-360°
Worktable load / Tool:	15 kg. / 7 kg.	R-axis 15 kg. / 4 kg.
Max. Speed X&Y / Z:	500 (mm/sec)	R-axis 360°/sec
Repeatability:	+/- 0.02mm Axis	R-axis ± 0.11°
Resolution:	0.001mm	
Data Memory:	100 Programs 20,000 step / 20,000 pts.	
Processor:	Main: 32bit, 1200 Mflops	
Drive Sys. / Servo:	3Ø AC Servo Motor 16Bit, 40 Mips	
Motion Control:	PTP & CP (3D Line, circle)	
Teaching Method:	Teach Pendant	
I/O Signals:	System I/O IN: 4, Out: 5 User I/O IN: 16, Out: 15	
External Interface:	RS232-C 2ch	
Power Supply:	AC 220V	
Dimensions (mm) (WxDxH):	604 x 680 x 730	
Weight:	123.2 lbs (56 kg)	

Dimensions

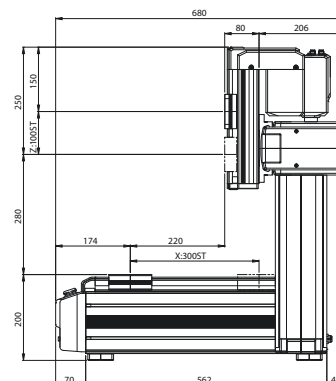
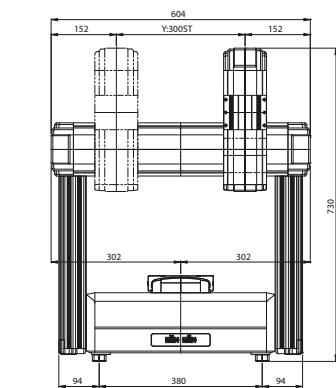

F3400N 3 & 4 - Axes Servo

Working Area 400 x 400mm

Exacta



Features

- Robust ball-screw servo motor drives
- Ideal for form-in-place gaskets, adhesives, potting, coating and filling
- High resolution 0.001mm
- Performs continuous path and point-to-point motions
- Quick fluid-purge button located on front panel
- Software tip alignment routine for quick program offsets when changing dispensing tips
- Step-and-repeat functions - program one object only for multiple identical objects
- On board 100 programs, 1,000 points per program
- Memory capacity, 20,000 steps / 20,000 points

The model F3400N is a RoHS compliant 15.74" x 15.74" (400 x 400mm) benchtop robot. It's servo motor driven ball-screw design enables closed loop operation. A rugged aluminum structure helps prevent vibration while maintaining a compact style and functionality, providing a precision multiple axis robot ideal for many bench dispensing projects. Resolution is 1 micron and interpolation is in all axes. The F3400N has been engineered to accept a tool weight of up to 7kg and 4kg for the 4-axes model with a worktable load of 15 kg, making the system tough enough for a wide range of automated dispensing applications.

Dimensions

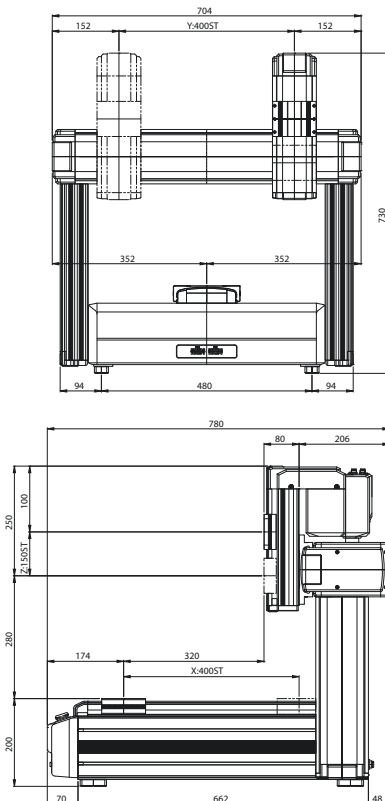

Model

F3400N Robot 3-axes 220V
F3404N Robot 4-axes 220V

Accessories (optional)

DSP501LF Dispenser

Specifications

X/Y/Z Work area (mm):	400 / 400 / 150	R-axis +/-360°
Worktable load / Tool:	15 kg. / 7 kg.	R-axis 15 kg / 4 kg
Max. Speed X&Y / Z:	500 (mm/sec)	R-axis 360°/sec
Repeatability:	+/- 0.02mm Axis	R-axis ± 0.11°
Resolution:	0.001mm	
Data Memory:	100 Programs 20,000 step / 20,000 pts.	
Processor:	Main: 32bit, 1200 Mflops	
Drive Sys. / Servo:	3Ø AC Servo Motor 16Bit, 40 Mips	
Motion Control:	PTP & CP (3D Line, circle)	
Teaching Method:	Teach Pendant	
I/O Signals:	System I/O IN: 4, Out: 5 User I/O IN: 16, Out: 15	
External Interface:	RS232-C 2ch	
Power Supply:	AC 220V	
Dimensions (mm) (WxDxH):	704 x 780 x 730	
Weight:	143 lbs (65 kg)	

F3000N - Dual Station Models

Dual Operation



Features

- Dual station operation
- Select from 300mm x 500mm or 400mm x 600mm systems
- Robust ball-screw servo motor drives
- Ideal for form-in-place gaskets, adhesives, potting, coating and filling
- High resolution 0.001mm
- Performs continuous path and point-to-point motions
- Quick fluid-purge button located on front panel
- Software tip alignment routine for quick program offsets when changing dispensing tips
- Step-and-repeat functions – program one object only for multiple identical objects
- On board 100 programs, 1,000 points per program
- Memory capacity, 20,000 steps / 20,000 points



F3000N Exacta 3 axes dual station systems include two independent working areas. Ideal for fast change over of identical parts or two dispensing operations. A servo motor driven ball-screw design enables closed loop operation. A rugged aluminum structure helps prevent vibration while maintaining a compact style and functionality, providing a precision multiple axes robot ideal for many bench dispensing projects. Resolution is 1 micron and interpolation is in all axes. F3000N robots have been engineered to accept a tool weight of up to 7kg and a worktable load of 15 kg, making the F3000N tough enough for a wide range of automated dispensing applications.

Model

F3350N 300 x 500 DS 3-axes 220V
 F3460N 400 x 600 DS 3-axes 220V

Specifications

W+X/Y/Z Work area (mm):	300 / 300 / 500 / 100 400 / 400 / 600 / 100
Worktable load / Tool:	15 kg. / 7 kg. + 15 kg. / 7 kg.
Max. Speed All Axes:	500 (mm/sec)
Repeatability:	+/- 0.02mm Axis
Resolution:	0.001mm
Data Memory:	100 Programs 20,000 step / 20,000 pts.
Processor:	Main: 32bit, 1200 Mflops
Drive Sys. / Servo:	3Ø AC Servo Motor 16Bit, 40 Mips
Motion Control:	PTP & CP (3D Line, circle)
Teaching Method:	Teach Pendant
I/O Signals:	System I/O In: 4, Out: 5 User I/O In: 16, Out: 15
External Interface:	RS232-C 2ch
Power Supply:	AC 220V
Dimensions (mm) (WxDxH):	804 x 680 x 730 904 x 780 x 730
Weight:	165 lbs (75 kg) 209 lbs (95 kg)

Dimensions (F3460N)

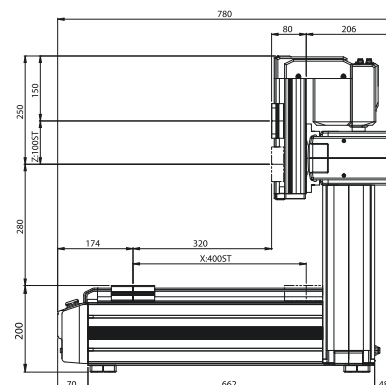
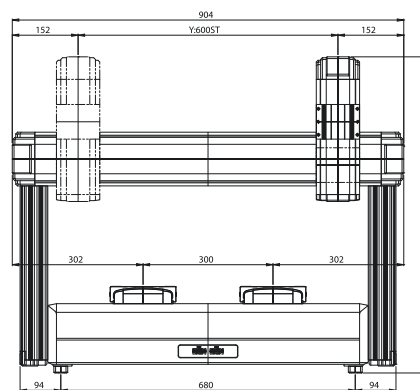

Exacta

F2200N - 3 & 4 Axes

Working Area 200 x 200mm



Features

- Ideal for form-in-place gaskets, adhesives, potting, coating and filling
- Repeatability 0.006mm for perfect dispensing
- Performs continuous path and point-to-point motions
- System includes 16 I/O signal interface for connection to tools and controllers
- Software tip alignment routine for quick program offsets when changing dispensing tips
- Step-and-repeat functions – program one object only for multiple identical objects
- On board 255 programs, 30,000 point memory capacity
- Fast, accurate and reliable 24 hours a day

The model F2200N is extremely economical on bench space, occupying a footprint of only 12.60 x 15.25 inches (320 x 387.5mm). Simple to program using a teach pendant or optional Windows® software. This cartesian robot automatically interpolates lines and curves in all axes. The model F2204N also includes a 4th axis for tool rotation. The powerful yet user-friendly software provides simple prompts, allowing programs to be created quickly and easily. It is possible to program and be operational within minutes.

Dimensions

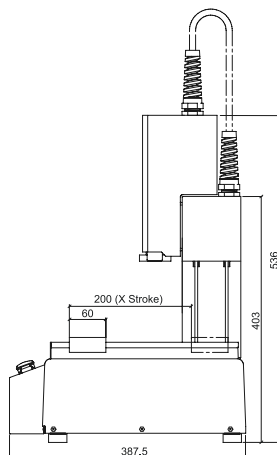
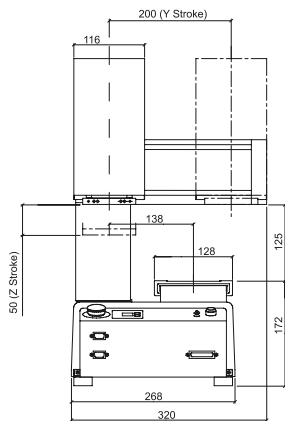

Model

F2200N-1	Robot 3-axes 110V
F2200N-1CE	Robot 3-axes 110V CE
F2204N-1	Robot 4-axes 110V
F2204N-1CE	Robot 4-axes 110V CE
F2200N-2	Robot 3-axes 220V
F2200N-2CE	Robot 3-axes 220V CE
F2204N-2	Robot 4-axes 220V
F2204N-2CE	Robot 4-axes 220V CE

Accessories (optional)

DSP501LF	Dispenser
F2000N-WIN	Windows® software package

Specifications

X/Y/Z Work area (mm):	200 / 200 / 50	4th axis +/-360°
Worktable load / Tool:	7 kg. / 3.5 kg.	
Max. Speed X&Y / Z:	700 / 250 (mm/sec)	4th axis 600°/sec
Resolution X&Y / Z (mm):	0.005 / 0.0025	4th axis 0.009°
Repeatability:	3-axis: +/- 0.006mm/Axis 4-axis: +/-0.01mm/Axis, R-axis: 0.004°	
Data Memory:	255 Programs, 30,000 Points	
PLC:	100 programs, 1000 steps per program	
Drive Sys. / Stepping motor:	5-phase stepping motor	
Motion Control:	PTP & CP	
Teaching Method:	Teach Pendant	
I/O signals:	16 inputs / 16 outputs	
External Interface:	RS232	
Power Supply:	110V: AC 90-132V 220V: AC 180-250V	
Dimensions (WxDxH):	3-axis: 320 x 387.5 x 536mm 4-axis: 320 x 387.5 x 655mm	
Weight:	3-axis: 39.6 lbs (18 kg) 4-axis: 44 lbs (20 kg)	

F2300N - 3 & 4 Axes

Working Area 300 x 320mm

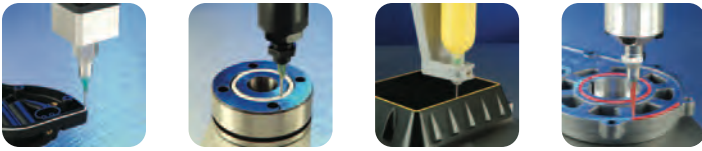

Features

- Ideal for form-in-place gaskets, adhesives, potting, coating and filling
- Repeatability 0.007mm for perfect dispensing
- Performs continuous path and point-to-point motions
- System includes 16 I/O signal interface for connection to tools and controllers
- Software tip alignment routine for quick program offsets when changing dispensing tips
- Step-and-repeat functions – program one object only for multiple identical objects
- On board 255 programs, 30,000 point memory capacity
- Fast, accurate and reliable 24 hours a day



The F2300N is a popular robot in the Cartesian range, with a working area of 11.81 x 12.60 inches (300 x 320mm). The system is easily programmed using a teach pendant or optional Windows® software. This cartesian robot automatically interpolates lines and curves in all axes. The model F2304N also includes a 4th axis for tool rotation. The powerful yet user-friendly software provides simple prompts, allowing programs to be created quickly and easily. It is possible to program and be operational within minutes.

Model

F2300N-1	Robot 3-axes 110V
F2300N-1CE	Robot 3-axes 110V CE
F2304N-1	Robot 4-axes 110V
F2304N-1CE	Robot 4-axes 110V CE
F2300N-2	Robot 3-axes 220V
F2300N-2CE	Robot 3-axes 220V CE
F2304N-2	Robot 4-axes 220V
F2304N-2CE	Robot 4-axes 220V CE

Accessories (optional)

DSP501LF	Dispenser
F2000N-WIN	Windows® software package

Specifications

X/Y/Z Work area (mm):	300 / 320 / 100	4th axis +/-360°
Worktable load / Tool:	11 kg. / 6 kg.	
Max. Speed X&Y / Z:	800 / 320 (mm/sec)	4th axis 800°/sec
Resolution X&Y / Z (mm):	0.005 / 0.0025	4th axis 0.009°
Repeatability:	3-axis: +/- 0.007mm/Axis 4-axis: +/-0.01mm/Axis, R-axis: 0.004°	
Data Memory:	255 Programs, 30,000 Points	
PLC:	100 programs, 1000 steps per program	
Drive Sys. / Stepping motor:	5-phase stepping motor	
Motion Control:	PTP & CP	
Teaching Method:	Teach Pendant	
I/O signals:	16 inputs / 16 outputs	
External Interface:	RS232	
Power Supply:	110V: AC 90-132V 220V: AC 180-250V	
Dimensions (WxDxH):	3-axis: 560 x 529 x 649mm 4-axis: 560 x 529 x 840mm	
Weight:	3-axis: 77 lbs (35 kg) 4-axis: 79.2 lbs (36 kg)	

Dimensions

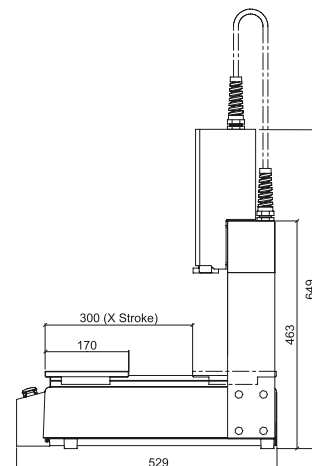
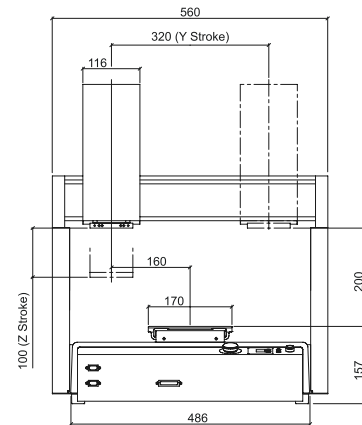

F2400N - 3 & 4 Axes

Working Area 400 x 400mm



Features

- Ideal for form-in-place gaskets, adhesives, potting, coating and filling
- Repeatability 0.007mm for perfect dispensing
- Performs continuous path and point-to-point motions
- System includes 16 I/O signal interface for connection to tools and controllers
- Software tip alignment routine for quick program offsets when changing dispensing tips
- Step-and-repeat functions – program one object only for multiple identical objects
- On board 255 programs, 30,000 point memory capacity
- Fast, accurate and reliable 24 hours a day

The F2400N has a work area of 15.75 x 15.75 inches (400 x 400mm), but the footprint is less than 25 inches (629mm) square for mounting on a standard workbench. The system is easily programmed using a teach pendant or optional Windows® software. This cartesian robot automatically interpolates lines and curves in all axes. The model F2204N also includes a 4th axis for tool rotation. The powerful yet user-friendly software provides simple prompts, allowing programs to be created quickly and easily. It is possible to program and be operational within minutes.

Dimensions

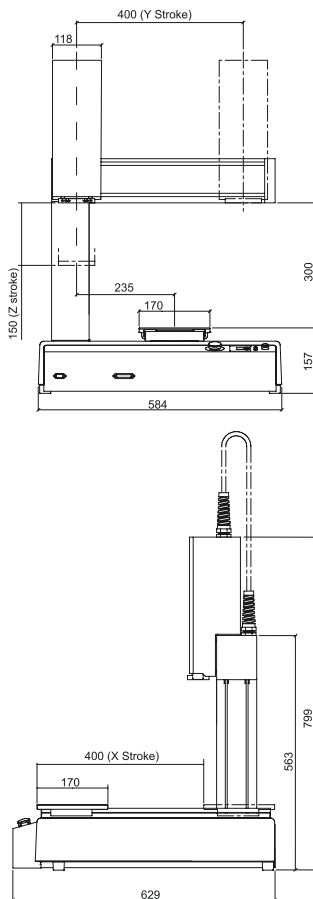

Model

F2400N-1	Robot 3-axes 110V
F2400N-1CE	Robot 3-axes 110V CE
F2404N-1	Robot 4-axes 110V
F2404N-1CE	Robot 4-axes 110V CE
F2400N-2	Robot 3-axes 220V
F2400N-2CE	Robot 3-axes 220V CE
F2404N-2	Robot 4-axes 220V
F2404N-2CE	Robot 4-axes 220V CE

Accessories (optional)

DSP501LF	Dispenser
F2000N-WIN	Windows® software package

Specifications

X/Y/Z Work area (mm):	400 / 400 / 150	4th axis +/-360°
Worktable load / Tool:	11 kg. / 6 kg.	
Max. Speed X&Y / Z:	800 / 320(mm/sec)	4th axis 800°/sec
Resolution X&Y / Z (mm):	0.005 / 0.0025	4th axis 0.009°
Repeatability:	3-axis: +/- 0.007mm/Axis 4-axis: +/- 0.01mm/Axis, R-axis: 0.004°	
Data Memory:	255 Programs, 30,000 Points	
PLC:	100 programs, 1000 steps per program	
Drive Sys. / Stepping motor:	5-phase stepping motor	
Motion Control:	PTP & CP	
Teaching Method:	Teach Pendant	
I/O signals:	16 inputs / 16 outputs	
External Interface:	RS232	
Power Supply:	110V: AC 90-132V 220V: AC 180-250V	
Dimensions (WxDxH):	3-axis: 584 x 629 x 799mm 4-axis: 584 x 629 x 890mm	
Weight:	3-axis: 92.4 lbs (42 kg) 4-axis: 94.6 lbs (43 kg)	

F2500N - 3 & 4 Axes

Working Area 510 x 510mm

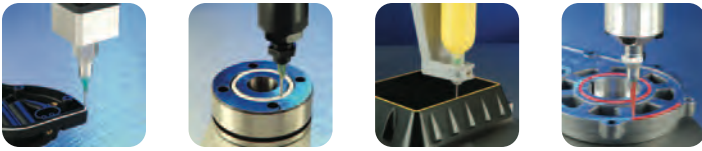

Features

- Ideal for form-in-place gaskets, adhesives, potting, coating and filling
- Repeatability 0.008mm for perfect dispensing
- Performs continuous path and point-to-point motions
- System includes 16 I/O signal interface for connection to tools and controllers
- Software tip alignment routine for quick program offsets when changing dispensing tips
- Step-and-repeat functions – program one object only for multiple identical objects
- On board 255 programs, 30,000 point memory capacity
- Fast, accurate and reliable 24 hours a day



The F2500N has a work area of 20.07 x 20.07 inches (510 x 510mm), but the footprint is less than 25 inches (629mm) square for mounting on a standard workbench. The F2500N Cartesian robot is open on one side allowing large objects to be easily handled in and out of the work area. The system automatically interpolates lines and curves in all axes and the model F2504N also includes a 4th axis for tool rotation. The powerful yet user-friendly software provides simple prompts, allowing programs to be created quickly and easily. It is possible to program and be operational within minutes.

Model

F2500N-1	Robot 3-axes 110V
F2500N-1CE	Robot 3-axes 110V CE
F2504N-1	Robot 4-axes 110V
F2504N-1CE	Robot 4-axes 110V CE
F2500N-2	Robot 3-axes 220V
F2500N-2CE	Robot 3-axes 220V CE
F2504N-2	Robot 4-axes 220V
F2504N-2CE	Robot 4-axes 220V CE

Accessories (optional)

DSP501LF	Dispenser
F2000N-WIN	Windows® software package

Specifications

X/Y/Z Work area (mm):	510 / 510 / 150	4th axis +/-360°
Worktable load / Tool:	11 kg. / 6 kg.	
Max. Speed X&Y / Z:	800 / 320 (mm/sec)	4th axis 800°/sec
Resolution X&Y / Z (mm):	0.005 / 0.0025	4th axis 0.009°
Repeatability:	3-axis: +/- 0.008mm/Axis 4-axis: +/-0.01mm/Axis, R-axis: 0.004°	
Data Memory:	255 Programs, 30,000 Points	
PLC:	100 programs, 1000 steps per program	
Drive Sys. / Stepping motor:	5-phase stepping motor	
Motion Control:	PTP & CP	
Teaching Method:	Teach Pendant	
I/O signals:	16 inputs / 16 outputs	
External Interface:	RS232	
Power Supply:	110V: AC 90-132V 220V: AC 180-250V	
Dimensions (WxDxH):	3-axis: 676 x 728 x 799mm 4-axis: 676 x 728 x 890mm	
Weight:	3-axis: 94.6 lbs (43 kg) 4-axis: 96.8 lbs (44 kg)	

Dimensions

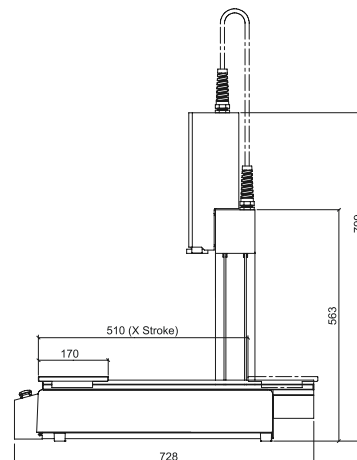
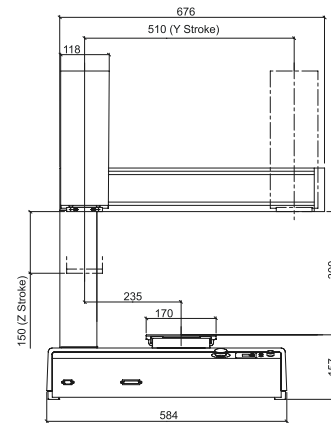

F9300N - 3 & 4 Axes Servo Cantilever

Working Area 300 x 300mm



Features

- Customized sizes available
- Robust ball-screw servo motor drives
- Ideal for form-in-place gaskets, adhesives, potting, solar junctions, stringers, coating, frame sealing and filling
- Resolution 0.001mm
- Performs continuous path and point-to-point motions
- Self contained controller functions
- Software tip alignment routine for quick program offsets when changing dispensing tips
- Step-and-repeat functions – program one object only for multiple identical objects
- On board 100 programs, 3,000 points per program
- Optional bar code scanning software

The model F9300N is a RoHS compliant 11.81" x 11.81" (300 x 300mm) gantry cantilever style robot. It's servo motor driven ball-screw design enables closed loop operation. A rugged aluminum structure helps prevent vibration while maintaining a compact style and functionality, providing a precision multiple axis robot ideal for conveyor fed applications, such as solar modules. Many projects also require all moving axes to be above the work station, the F9300N provides that capability. Resolution is 1 micron and interpolation is in all axes. The F9300N has been engineered to accept a tool weight of up to 7kg and 4kg for the 4-axes model.

Dimensions

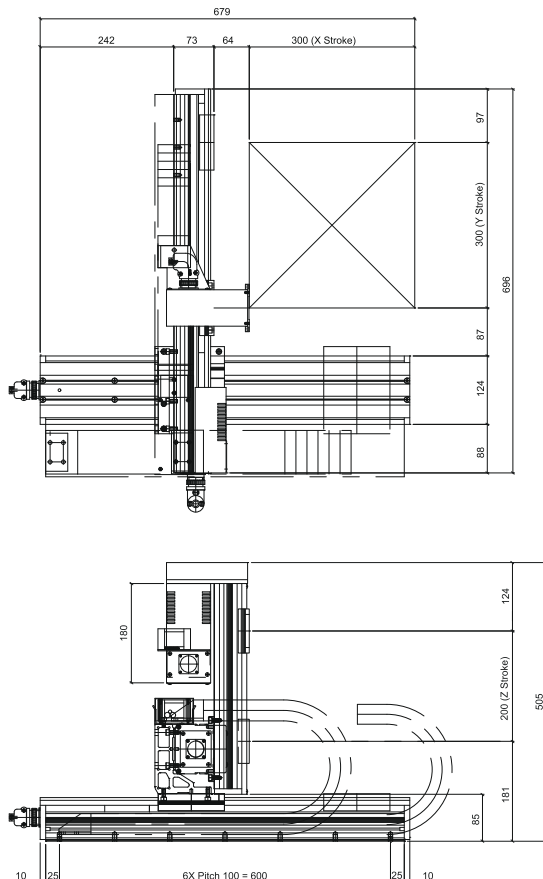

Model

F9300N	Robot 3-axes 220V
F9304N	Robot 4-axes 220V

Accessories (optional)

DSP501LF	Dispenser
F9000N-WIN	Windows® software package

Mounting Supports (two required each side)

Main	Height	Qty
562022-050	50mm	1
562022-100	100mm	1
562022-150	150mm	1

Specifications

X/Y/Z Work area (mm):	300 / 300 / 200	R-axis +/-360°
Maximum tool load:	7 kg.	R-axis 4 kg.
Max. Speed X&Y / Z:	1000 / 1000 / 500 (mm/sec)	R-axis 360°/sec
Repeatability:	+/- 0.02mm/ Axis	R-axis ± 0.05°
Resolution:	0.001mm	R-axis ± 0.001°
Data Memory:	100 Programs	
	3,000 step / PGM	
Processor:	Main: 32bit, 900 mflops	
Drive Sys. / Servo:	3Ø AC Servo Motor 16Bit, 40mips	
Motion Control:	PTP & CP (3D Line, circle)	
Teaching Method:	Teach Pendant	
I/O Signals:	System I/O IN: 24, Out: 6	
	User I/O IN: 32, Out: 32	
External Interface:	RS232	
Power Supply:	2Ø AC220V - 500VA (600VA)	
Dimensions (WxDxH):	679 x 696 x 505	
Weight:	63.8 lbs (29 kg)	

F9600N - 3 & 4 Axes Servo Gantry

Working Area 600 x 600mm

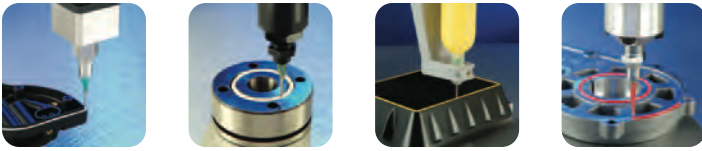

Gantry

Features

- Customized sizes available
- Robust ball-screw servo motor drives
- Ideal for form-in-place gaskets, adhesives, potting, solar junctions, stringers, coating, frame sealing and filling
- Resolution 0.001mm
- Performs continuous path and point-to-point motions
- Self contained controller functions
- Software tip alignment routine for quick program offsets when changing dispensing tips
- Step-and-repeat functions – program one object only for multiple identical objects
- On board 100 programs, 3,000 points per program
- Optional bar code scanning software

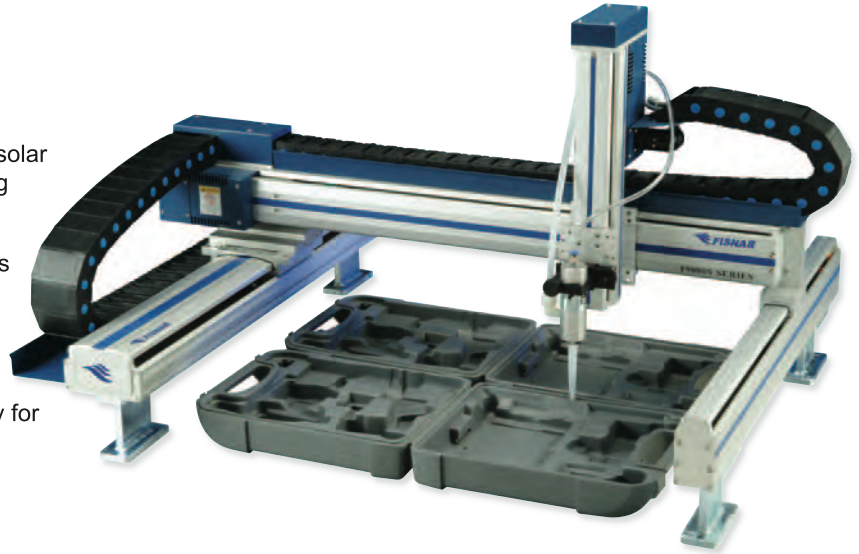

The model F9600N is a RoHS compliant 23.62" x 23.62" (600 x 600mm) gantry style robot. It's servo motor driven ball-screw design enables closed loop operation. A rugged aluminum structure helps prevent vibration while maintaining a compact style and functionality, providing a precision multiple axis robot ideal for conveyor fed applications, such as solar modules. Many projects also require all moving axes to be above the work station, the F9600N provides that capability. Resolution is 1 micron and interpolation is in all axes. The F9600N has been engineered to accept a tool weight of up to 7kg and 4kg for the 4-axes model.

Model

F9600N	Robot 3-axes 220V
F9604N	Robot 4-axes 220V

Dimensions

Accessories (optional)

DSP501LF	Dispenser
F9000N-WIN	Windows® software package

Mounting Supports (two required each side)

Main (Left Side)	Idle (Right Side)	Height	Qty
562022-050	562023-050	50mm	1
562022-100	562023-100	100mm	1
562022-150	562023-150	150mm	1

Specifications

X/Y/Z Work area (mm):	600 / 600 / 200	R-axis +/-360°
Maximum tool load:	7 kg.	R-axis 4 kg.
Max. Speed X&Y / Z:	1000 / 1000 / 500 (mm/sec)	R-axis 360°/sec
Repeatability:	+/- 0.02mm/ Axis	R-axis ± 0.05°
Resolution:	0.001mm	R-axis ± 0.001°
Data Memory:	100 Programs 3,000 step / PGM	
Processor:	Main: 32bit, 900 mflps	
Drive Sys. / Servo:	3Ø AC Servo Motor 16Bit, 40mips	
Motion Control:	PTP & CP (3D Line, circle)	
Teaching Method:	Teach Pendant	
I/O Signals:	System I/O IN: 24, Out: 6 User I/O IN: 32, Out: 32	
External Interface:	RS232	
Power Supply:	2Ø AC220V - 500VA (600VA)	
Dimensions (WxDxH):	979 x 1022 x 505	
Weight:	81.4 lbs (37 kg)	

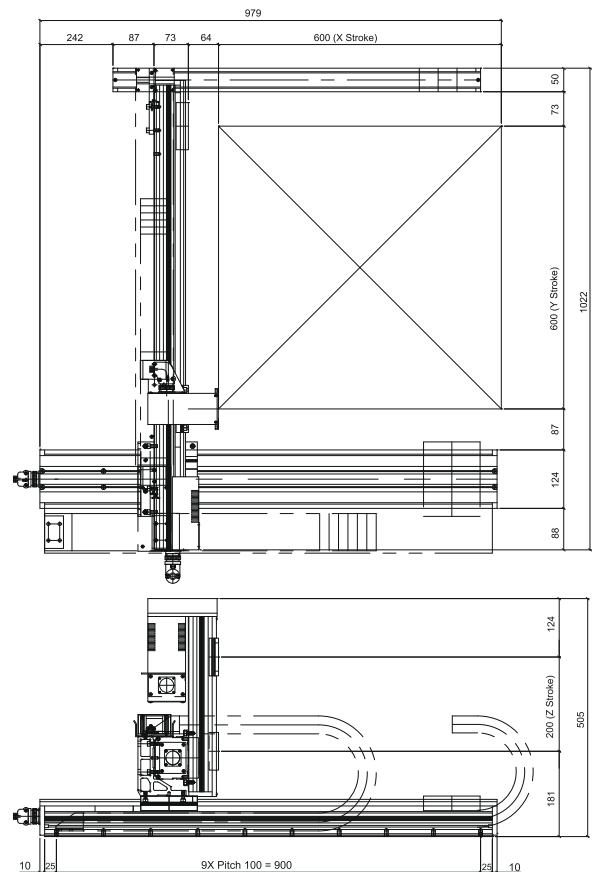

F9800N - 3 & 4 Axes Servo Gantry

Working Area 800 x 600mm



Gantry



Features

- Customized sizes available
- Robust ball-screw servo motor drives
- Ideal for form-in-place gaskets, adhesives, potting, solar junctions, stringers, coating, frame sealing and filling
- Resolution 0.001mm
- Performs continuous path and point-to-point motions
- Self contained controller functions
- Software tip alignment routine for quick program offsets when changing dispensing tips
- Step-and-repeat functions - program one object only for multiple identical objects
- On board 100 programs, 3,000 points per program
- Optional bar code scanning software

The model F9800N is a RoHS compliant 31.50" x 23.62" (800 x 600mm) gantry style robot. It's servo motor driven ball-screw design enables closed loop operation. A rugged aluminum structure helps prevent vibration while maintaining a compact style and functionality, providing a precision multiple axis robot ideal for conveyor fed applications, such as solar modules. Many projects also require all moving axes to be above the work station, the F9800N provides that capability. Resolution is 1 micron and interpolation is in all axes. The F9800N has been engineered to accept a tool weight of up to 7kg and 4kg for the 4-axes model.

Dimensions

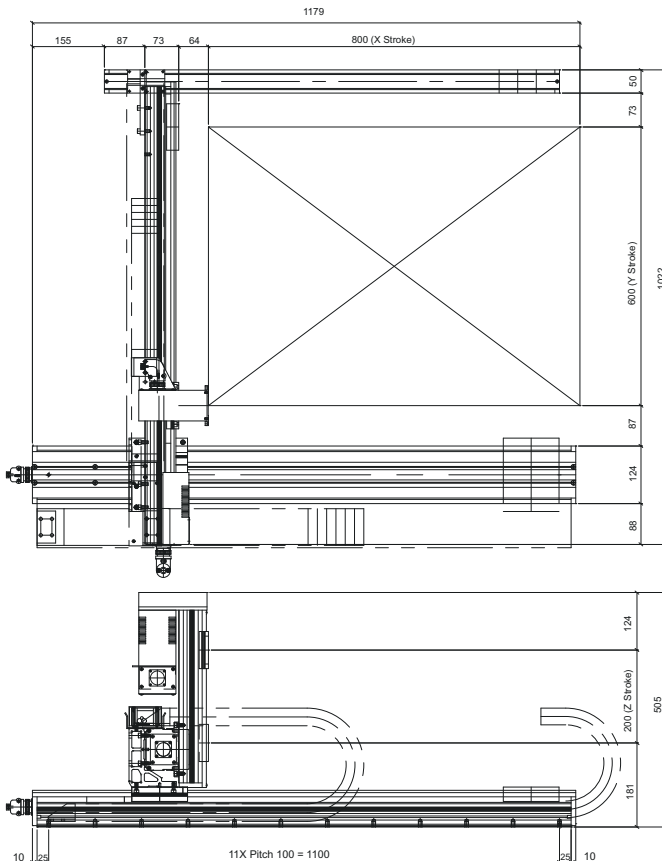

Model

F9800N	Robot 3-axes 220V
F9804N	Robot 4-axes 220V

Accessories (optional)

DSP501LF	Dispenser
F9000N-WIN	Windows® software package

Mounting Supports (three required each side)

Main (Left Side)	Idle (Right Side)	Height	Qty
562022-050	562023-050	50mm	1
562022-100	562023-100	100mm	1
562022-150	562023-150	150mm	1

Specifications

X/Y/Z Work area (mm):	800 / 600 / 200	R-axis +/-360°
Maximum tool load:	7 kg.	R-axis 4 kg.
Max. Speed X&Y / Z:	1000 / 1000 / 500 (mm/sec)	R-axis 360°/sec
Repeatability:	+/- 0.02mm/ Axis	R-axis ± 0.05°
Resolution:	0.001mm	R-axis ± 0.001°
Data Memory:	100 Programs 3,000 step / PGM	
Processor:	Main: 32bit, 900 mflops	
Drive Sys. / Servo:	3Ø AC Servo Motor 16Bit, 40mips	
Motion Control:	PTP & CP (3D Line, circle)	
Teaching Method:	Teach Pendant	
I/O Signals:	System I/O IN: 24, Out: 6 User I/O IN: 32, Out: 32	
External Interface:	RS232	
Power Supply:	2Ø AC220V - 500VA (600VA)	
Dimensions (mm) (WxDxH):	1179 x 1022 x 505	
Weight:	94.6 lbs (43 kg)	

F9250N - 3 & 4 Axes Servo Gantry - Solar

Working Area 2500 x 1500mm

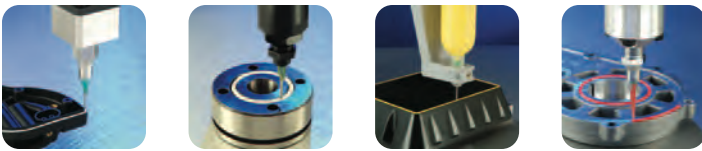

Gantry

Features

- Large Area - **Customized sizes available up to 7 meters**
- Robust ball-screw servo motor drives
- Ideal for solar panel fabrication
- Junctions, stringers, potting, coating, frame sealing, gaskets
- Resolution 0.001mm
- Performs continuous path and point-to-point motions
- Self contained controller functions
- Software tip alignment routine for quick program offsets when changing dispensing tips
- Step-and-repeat functions - program one object only for multiple identical objects
- On board 100 programs, 3,000 points per program
- Optional bar code scanning software

The model F9250N is a RoHS compliant 98.42" x 59.05" (2500 x 1500mm) gantry style robot. It's servo motor driven ball-screw design enables closed loop operation. A rugged and reinforced aluminum structure helps prevent vibration while maintaining a compact style and functionality, providing a precision multiple axis robot ideal for conveyor fed applications, such as solar modules. Many projects also require all moving axes to be above the work station, the F9250N provides that capability. Resolution is 1 micron and interpolation is in all axes. The F9250N has been engineered to accept a tool weight of up to 7kg and 4kg for the 4-axes model.

Model

F9250N Robot 3-axes 220V
 F9254N Robot 4-axes 220V

Accessories (optional)

DSP501LF Dispenser
 F9000N-WIN Windows® software package

Mounting Supports (seven required each side)

Main (Left & Right Side)	Height	Qty
562022-050	50mm	1
562022-100	100mm	1
562022-150	150mm	1

Specifications

X/Y/Z Work area (mm):	2500 / 1500 / 200	R-axis +/-360°
Maximum tool load:	7 kg.	R-axis 4 kg.
Max. Speed X&Y / Z:	1000 / 1000 / 500 (mm/sec)	R-axis 360°/sec
Repeatability:	+/- 0.02mm/ Axis	R-axis ± 0.05°
Resolution:	0.001mm	R-axis ± 0.001°
Data Memory:	100 Programs 3,000 step / PGM	
Processor:	Main: 32bit, 900 mflops	
Drive Sys. / Servo:	3Ø AC Servo Motor 16Bit, 40mips	
Motion Control:	PTP & CP (3D Line, circle)	
Teaching Method:	Teach Pendant	
I/O Signals:	System I/O IN: 24, Out: 6 User I/O IN: 32, Out: 32	
External Interface:	RS232	
Power Supply:	2Ø AC220V - 500VA (600VA)	
Dimensions (mm) (WxDxH):	3160 x 2420 x 930	
Weight:	335 lbs (152.27 kg)	



F8800N - 3 & 4 Axes Servo Cantilever

Working Area 800 x 600mm



Features

- Compact open access design
- Highly rigid frame structure
- Ideal for form-in-place gaskets, adhesives, potting, coating and filling
- Positioning repeatability 0.02mm
- Performs continuous path and point-to-point motions
- AC servo motors and ball-screw design
- Software tip alignment routine for quick program offsets when changing dispensing tips
- Step-and-repeat functions – program one object only for multiple identical objects
- On board 100 programs, 1,000 points per program
- Memory capacity, 20,000 steps / 20,000 points

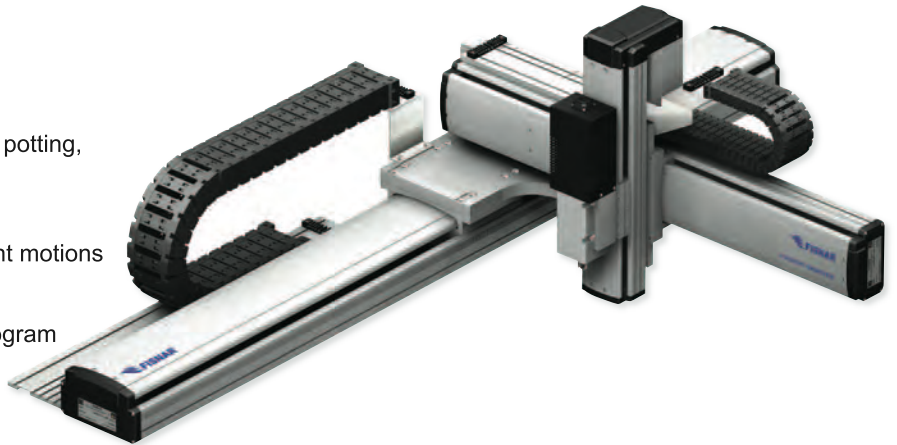

The model F8800N is a RoHS compliant 31.50" x 23.62" (800 x 600mm) cantilever open access style robot. It's servo motor driven ball-screw design enables closed loop operation. A specially ruggedized aluminum structure prevents flexing and vibration while maintaining functionality, providing a precision multiple axis robot ideal for conveyor fed applications. Many projects also require all moving axes to be above the work station, the F8800N provides that capability. Resolution is 1 micron and interpolation is in all axes. The F8800N has been engineered to accept a tool weight of up to 5kg and 2kg for the 4-axes model.

Dimensions

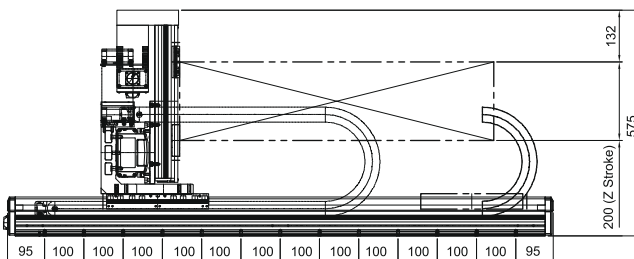
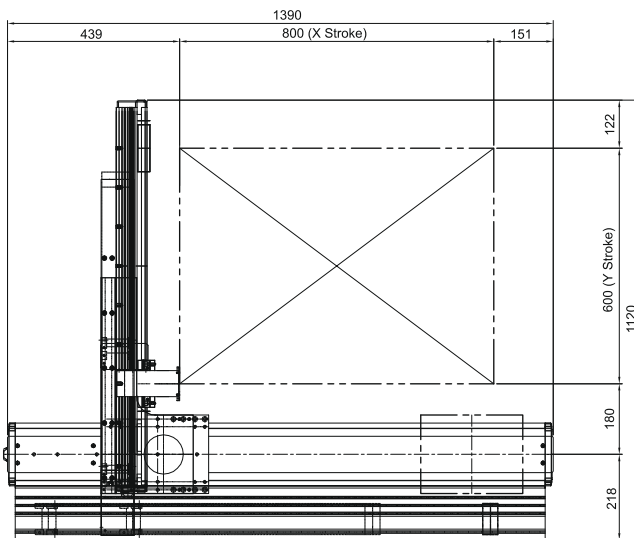

Model

F8800N Robot 3-axes 220V
F8804N Robot 4-axes 220V

Mounting Supports (optional)

(three required)

Main	Height	Qty
562024-050	50mm	1
562024-100	100mm	1
562024-150	150mm	1

Specifications

X/Y/Z Work area (mm):	800 / 600 / 200	R-axis +/-360°
Maximum Tool Load:	5 kg.	R-axis 2 kg.
Body Frame X-axis:	120mm - 200mm	
Body Frame Y-axis:	90mm - 160mm	
Max. Speed X&Y / Z:	1000 / 1000 / 500 (mm/sec)	R-axis 360°/sec
Repeatability:	+/- 0.02mm/ Axis	R-axis ± 0.058°
Resolution:	0.001mm	R-axis ± 0.001°
Run Out Y-axis:	0.1mm Full Travel	
Data Memory:	100 Programs	
	20,000 step / 20,000 points	
Processor:	Main: 32bit, 900 mflops	
Servo Output X-axis:	200 watt → 800 watt	
Servo Output Y-axis:	200 watt → 400 watt	
Motion Control:	PTP & CP (3D Line, circle)	
Teaching Method:	Teach Pendant	
I/O Signals:	System I/O IN: 24, Out: 6	
	User I/O IN: 32, Out: 32	
External Interface:	RS232	
Power Supply:	2Ø AC220V - 500VA (600VA)	
Dimensions (WxDxH):	1110 x 1380 x 565	
Weight:	3-axes: 159 lbs (72 kg)	
	4-axes: 179 lbs (81 kg)	

F8100N - 3 & 4 Axes Servo Cantilever

Working Area 1000 x 800mm

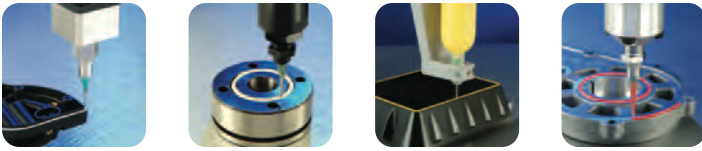

Cantilever

Features

- Compact open access design
- Highly rigid frame structure
- Ideal for form-in-place gaskets, adhesives, potting, coating and filling
- Positioning repeatability 0.02mm
- Performs continuous path and point-to-point motions
- AC servo motors and ball-screw design
- Software tip alignment routine for quick program offsets when changing dispensing tips
- Step-and-repeat functions - program one object only for multiple identical objects
- On board 100 programs, 1,000 points per program
- Memory capacity, 20,000 steps / 20,000 points

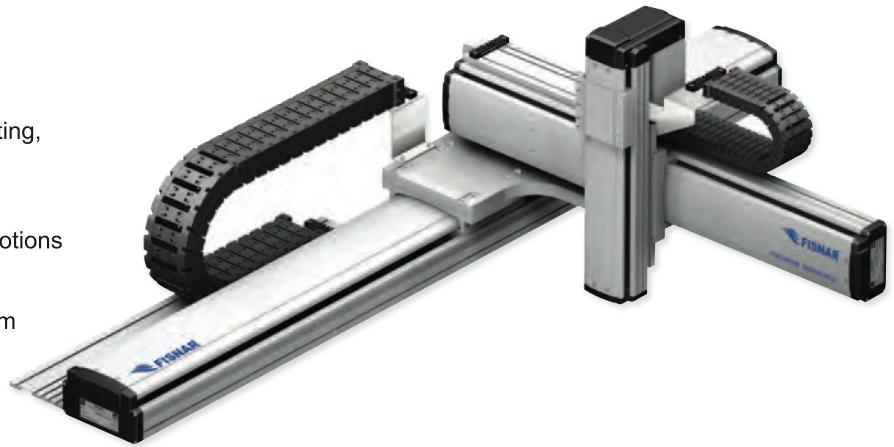

The model F8100N is a RoHS compliant 39.37" x 31.50" (1000 x 800mm) cantilever open access style robot. It's servo motor driven ball-screw design enables closed loop operation. A specially ruggedized aluminum structure prevents flexing and vibration while maintaining functionality, providing a precision multiple axis robot ideal for conveyor fed applications. Many projects also require all moving axes to be above the work station, the F8100N provides that capability. Resolution is 1 micron and interpolation is in all axes. The F8100N has been engineered to accept a tool weight of up to 5kg and 2kg for the 4-axes model.

Model

F8100N Robot 3-axes 220V
 F8104N Robot 4-axes 220V

Mounting Supports (optional)

(four required)

Main	Height	Qty
562025-050	50mm	1
562025-100	100mm	1
562025-150	150mm	1

Specifications

X/Y/Z Work area (mm):	1000 / 800 / 200	R-axis +/-360°
Maximum Tool Load:	5 kg.	R-axis 2 kg.
Body Frame X-axis:	120mm - 200mm	
Body Frame Y-axis:	90mm - 160mm	
Max. Speed X&Y / Z:	1000 / 1000 / 500 (mm/sec)	R-axis 360°/sec
Repeatability:	+/- 0.02mm/ Axis	R-axis ± 0.058°
Resolution:	0.001mm	R-axis ± 0.001°
Run Out Y-axis:	0.13mm Full Travel	
Data Memory:	100 Programs 20,000 step / 20,000 points	
Processor:	Main: 32bit, 900 mflops	
Servo Output X-axis:	200 watt → 800 watt	
Servo Output Y-axis:	200 watt → 400 watt	
Motion Control:	PTP & CP (3D Line, circle)	
Teaching Method:	Teach Pendant	
I/O Signals:	System I/O IN: 24, Out: 6 User I/O IN: 32, Out: 32	
External Interface:	RS232	
Power Supply:	2Ø AC220V - 500VA (600VA)	
Dimensions (WxDxH):	1425 x 1630 x 628	
Weight:	3-axes: 254 lbs (115 kg) 4-axes: 273 lbs (124 kg)	

Dimensions

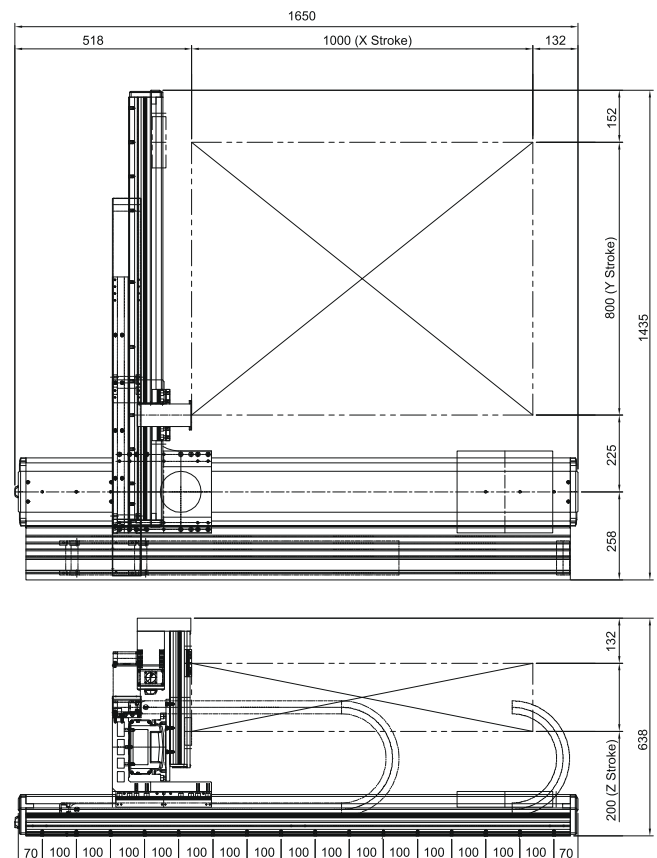

F2004N - Scara

Working Area 300 x 300mm



A 4 axes high-speed industrial SCARA robot ideal for high volume and large area dispensing applications requiring greater flexibility for automated manufacturing environments, including conveyors and work cells. Can also be used for pick & place applications.

Dimensions

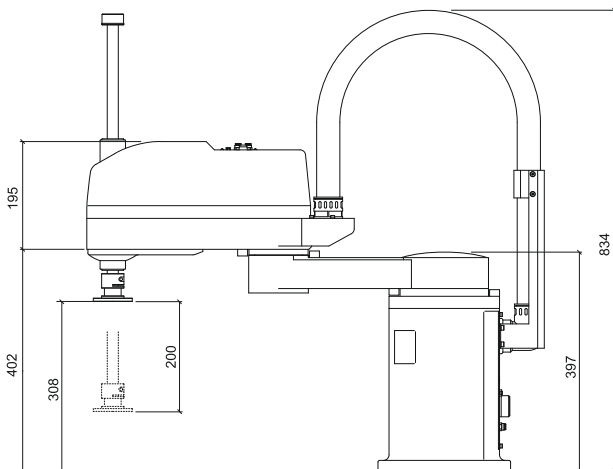
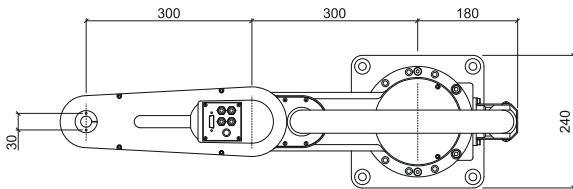

Features

- Highly rigid frame structure
- Ideal for form-in-place gaskets, adhesives, potting, coating, filling and pick & place procedures
- Positioning repeatability 0.02mm
- Performs continuous path and point-to-point motions
- AC servo motors
- Software tip alignment routine for quick program offsets when changing dispensing tips
- Digital servo controlled motors
- Multiple I/O communications
- High speed movement up to 5000mm/sec

Model

F2004N

Robot 4-axes 220V

Accessories (optional)

DSP501LF

Dispenser

F9000N-WIN

Windows® software package

Specifications

Rated/Max Payload:		2/7 kg
Arm Length:	J1 + J2 arm	300 x 300mm
Repeatability:	J1 + J2 arm	+/- 0.03mm
	J3	+/- 0.02mm
	J4	+/- 0.03°
Operating Range:	J1 arm	+/-125°
	J2	+/-125°
	J3	200mm
	J4	+/-360° R Axis 360°/sec
Max Speed (No Load):	J1 + J2 arm	5.6 m/s
	J3	1 m/s
	J4	720°/s
Allowable Inertia of J4:		0.003 kgf.m.s2
Type of Encoder:		Absolute
Program Capacity:		100 Programs
		3,000 step / 3,000 pts.
Drive System / Motor:		Full Digital AC servo
Motion Control:		PTP, CP
Linear/Circular Interpolation:		4-axes
Teaching Method:		Teach Pendant
Processor Main CPU:		32 bit *1 900 Mflops
Processor Servo CPU:		16 bit *2 40 Mips
Data Memory Type:		2MB Battery Backup SRAM
PLC:		10 Programs
		1,000 pts/program
I/O Signals:		System I/O IN: 24, Out: 6
		User I/O IN: 32, Out: 32
External Interface:		RS232C
Power Supply:		1ø AC220V
Dimensions (mm) (WxDxH):	Manipulator	240x828x834
	Controller	368x302x160
Weight:	Manipulator	81.6 lbs (37kg)
	Controller	22 lbs (10kg)

RT404-FLEXII - Dual Station Rotary Table

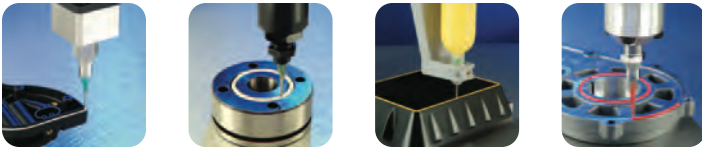

Working Diameter 152mm

Features

- Dispenses in circles from 0-900°
- Adjustable Z-axis including tilt control
- Variable speed table
- Simple to set up and operate
- Fully programmable for perfect dispensing

The RT404-FLEXII rotary table provides an efficient method of dispensing a circular pattern on areas that are difficult to access. The tilting Z-axis allows controlled rotary dispensing on an angle. The RT404-FLEXII dispenses adhesives, silicones, grease and lubricants and is fully adjustable in rotation speed, circle diameter and dispensing time. Dispense from barrels, cartridges or valves mounted on the Z-axis. The Z-axis tilt is easily adjusted to dispense either on a vertical wall within a cylindrical part or on an outside wall. The system is fully programmable to control dispense delay, rotation delay, degree of rotation and wait period before cycling.



Model

RT404-FLEXII-110 Rotary Table 110V
 RT404-FLEXII-220 Rotary Table 220V

Accessories (optional)

DSP501LF Dispenser 110/220V

Specifications

Dispenser:	DSP501LF (not included)
Cycle Initiation:	Manual or Automatic
Vertical Travel:	2.00" (50mm) other lengths optional
Rotation Speed:	0-60rpm
Air Input:	70-100 psi (5 - 7 bar)
Air Output:	1-100 psi (0.1 - 7 bar)
Dimensions (WxDxH):	635 x 643 x 850
Weight:	26.5 lbs (43 kg)

Z620 - Z-Axis Station

The Z620 is an ideal solution for repetitive filling, potting or other dispensing operations requiring z-axis control. The z-axis system will consistently dispense material to a specific height and can be integrated into an automated line or conveyor-fed station. Other features include adjustable tilt, speed and dispense time. The Z620 controller interfaces with the DSP501LF dispenser to complete the system.

Model

Z620 Auto-z dispenser 110/220V

Accessories (optional)

DSP501LF Dispenser 110/220V

Specifications

Power:	Switchable 110V or 220V, 50/60Hz
Stroke:	0.2" - 2.0" (5.08mm - 50mm)
Front to back positioning:	0" - 1.75" (0mm - 45mm)
Air Input:	60-90 psi (4 - 6 bar)
Controller Dimensions (WxDxH):	222 x 222 x 67mm
Unit Dimensions (WxDxH):	258 x 258 x 495mm
Weight:	22 lbs (10 kg)



